

Content	
1	NAUTIZ X2 LF Reader
2	Screw M2 X 6
2	Screw M1.6 x 16
4	O-Ring 1 x 1
1	O-Ring 10 x 1
Tools required	
1	Torx T5
1	Hex key 1.5

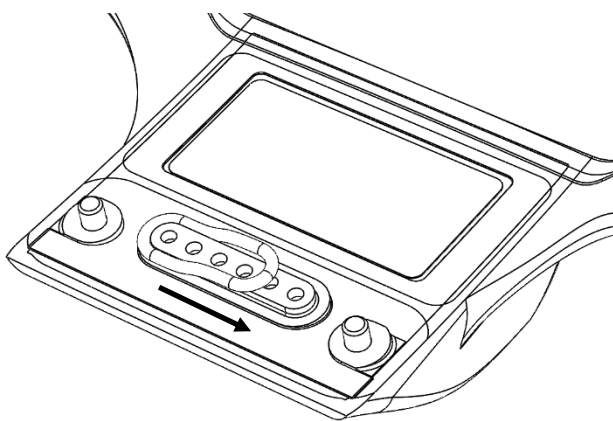
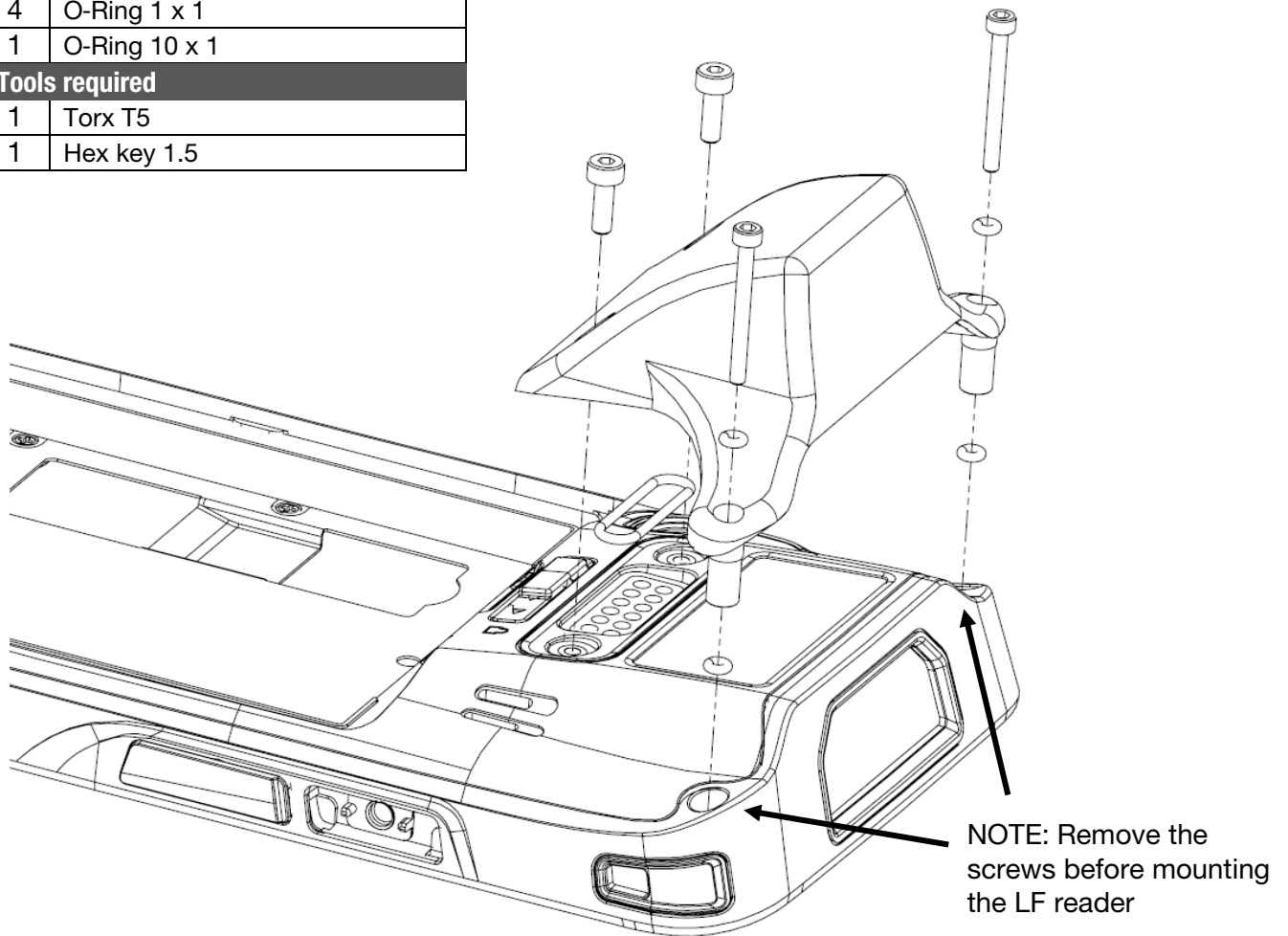

Placement of O-Ring 10x1

1. Twist O-Ring
2. Place in one corner
3. Twist back